

DOE/ET-53088-188

IFSR #188

**Ambipolarons: Solitary Wave Solutions for the
Radial Electric Field in a Plasma**

D.E. Hastings
Oak Ridge National Laboratory
Oak Ridge, Tennessee 37831

R.D. Hazeltine and P.J. Morrison[†]
Institute for Fusion Studies
The University of Texas at Austin
Austin, Texas 78712

June 1985

Ambipolarons: Solitary Wave Solutions for the Radial Electric Field in a Plasma

D.E. Hastings

Oak Ridge National Laboratory

Oak Ridge, Tennessee 37831

R.D. Hazeltine and P.J. Morrison[†]

Institute for Fusion Studies

The University of Texas at Austin

Austin, Texas 78712

Abstract

The ambipolar radial electric field in a nonaxisymmetric plasma can be described by a nonlinear diffusion equation. This equation is shown to possess solitary wave solutions. A model nonlinear diffusion equation with a cubic nonlinearity is studied. An explicit analytic step-like form for the solitary wave is found. It is shown that the solitary wave solutions are linearly stable against all but translational perturbations. Collisions of these solitary waves are studied and three possible final states are found: two diverging solitary waves, two stationary solitary waves or two converging solitary waves leading to annihilation.

[†] Also Department of Physics

I. Introduction

In recent years there has been growing interest in solitary waves and solitons since they are exact nonlinear solutions to certain classes of partial differential equations. Solitary waves are defined to be nonlinear solutions that propagate with a constant velocity (c). The shape of the solution may be step-like as in the nonlinear Klein-Gordon equation¹⁻⁴ or pulse-like as in the case of the regularized-long-wave equation.^{4,5} Sometimes solitary waves possess additional properties; for example, the velocity (c) can increase with the wave amplitude (A) and the width (k^{-1}) can decrease with the wave amplitude. Thus travelling shock wave type solutions are included in this definition. Solitons can be loosely defined to be solitary waves which have the further property that if a soliton interacts with another soliton then after the interaction the original structures are preserved and the velocities unchanged. Solitons have all or part of the inverse scattering machinery available for integration.⁶

In this paper we shall demonstrate that the radial electric field equation in a nonaxisymmetric torus possesses solitary wave solutions which we name ambipolarons. We find the specific analytic form for these ambipolarons for a well known model of the diffusion coefficients. We examine the linear stability of these solitary waves and show that they are stable except for translation. Finally we examine their interactions numerically and show they are not solitons; they lead to new structures when collided.

II. Solitary waves from the radial electric field equation

The radial electric field for a plasma confined in a nonaxisymmetric geometry is described by the radial component of Ampere's law combined with the continuity equations for density and temperature. In terms of the particle fluxes, this electric field equations is

$$\epsilon_{\perp} \frac{\partial E}{\partial t} = - \sum_a Z_a e \Gamma_a(E, n_a, T_a) + \epsilon_t^2 \frac{D}{r} \frac{\partial}{\partial r} \left(r \frac{\partial E}{\partial r} \right) \quad (1)$$

where E is the radial electric field, ϵ_{\perp} is the low frequency perpendicular dielectric function, Z_a is the charge number of species "a", and Γ_a is the particle flux of "a" which is a nonlinear function of E , the density n_a and temperature T_a . In the diffusion term $\epsilon_t \ll 1$ is the inverse aspect ratio, and D is the electric field diffusion coefficient⁷ arising from the finite orbit deviation from the flux surface and which satisfies $D = O(\sum_a Z_a e \Gamma_a / \partial^2 E / \partial r^2)$.

The diffusion equation in (1) is a nonlinear equation which has the property that $\sum_a Z_a \Gamma_a = 0$ may possess several real solutions.⁸ Typically in magnetic fusion applications $\sum_a Z_a \Gamma_a$ is found to have one or three real zeroes. It is of interest to study the types of solutions of (1) in order to gain insight into the difficult problem of solving (1) coupled with the (nonlinear) equations for the density and temperature.

It is easy to see that (1) allows solitary wave solutions. The macroscopic relaxation time of the electric field in (1) is $\tau_E = \epsilon_{\perp} / (\sum_a Z_a e \partial \Gamma_a / \partial E)$. For parameters typical of fusion experiments it is found that $\tau_E \ll \tau_p$ where τ_p is the relaxation time of the density and temperature. This means that if the electric field, density and temperature equations are started with arbitrary initial conditions, the electric field will relax first with the density and temperature in (1) being the initial conditions. The electric field will then change on the slow τ_p timescale as the density and temperature change. If E_1 and E_3 are two real solutions to $\sum_a Z_a \Gamma_a = 0$ and the initial condition on (1) is near E_1 in part of the space and near E_3 over the rest of the space then there will be a region of space where the initial conditions will vary from E_1 to E_3 . If this region is thin, that is, small compared to the macroscopic length-scale of the density and temperature (typically the plasma radius) then we can define a stretched variable $\eta = r / (\epsilon_t \sqrt{D})$ across this region and keep only second derivatives in (1) to obtain

$$\frac{\partial E}{\partial \hat{t}} = - \sum_a Z_a e \Gamma_a(E) + \frac{\partial^2 E}{\partial \eta^2}. \quad (2)$$

Here we define $\hat{t} = t / \epsilon_{\perp}$. Since $\eta \gg r(\epsilon_t \ll 1)$ we can extend the range of η from $-\infty$ to $+\infty$ and impose the boundary conditions on (2), $E \rightarrow E_1$ as $\eta \rightarrow -\infty$, $E \rightarrow E_3$ as $\eta \rightarrow +\infty$. In addition, since the density and temperature dependence in the flux varies on the long macroscopic length scale, this spatial variation can be neglected in (2) where we are concerned with the boundary layer for $\eta \sim 0(1)$ (hence $r = 0(\epsilon_t)$). We look for solutions of the form $u(z) = E(\eta - c\hat{t})$ where $z = \eta - c\hat{t}$ and c is an undetermined constant speed. On substitution of this form in (2), multiplication by du/dz and integration from $z = -\infty$ to $z = +\infty$ with the condition that $u' = du/dz \rightarrow 0$ as $z \rightarrow \pm\infty$ we obtain

$$c \int_{-\infty}^{\infty} (u')^2 dz = \int_{E_1}^{E_3} dE \sum_a Z_a e \Gamma_a(E) = V(E_3) - V(E_1) \quad (3)$$

where we define the potential $V(E)$ by $V(E) = \int^E dE \sum_a Z_a e \Gamma_a(E)$. This indicates that a real velocity c exists and hence a solitary wave solution to (1) is possible. Furthermore

we can see one of the solutions E_1 or E_3 is dominant in the sense that if $V(E_3) > V(E_1)$ then the solitary wave will propagate in such a way so as to create E_1 at the expense of E_3 . In this case E_1 is dominant. The opposite conclusion holds if $V(E_3) < V(E_1)$. We propose to call these solitary wave solutions ambipolarons in view of their origin in the calculation of the ambipolar electric field in a plasma. We observe that $V(E)$ was used in Ref. 9 to investigate stability of constant electric field solutions.

We note that nonlinear diffusion equations like (2) have been studied both for their mathematical content¹⁰ and as models for physical processes. These range from the spread of advantageous genetic traits in populations¹¹ (Fisher's equation) to signal propagation in bistable transmission lines¹² to pattern formation in diffusing and reacting media.¹³

III. A model equation for the radial electric field

In order to obtain an explicit analytic form for the ambipolaron we study a simple model of (1). If we consider a single ion-electron plasma and take a constant electron temperature T_e and constant ion temperature T_i then the flux for species a is $\Gamma_a = -D_{n_a} n(n'/n - Z_a E/T_a)$ where the density is $n = n_e = n_i$ and $n' = \partial n/\partial r$. We choose a model for D_{n_e} and D_{n_i} valid for a bumpy torus¹⁴

$$D_{n_a} = \frac{1}{12} \left(\frac{T_a}{B_o R_o} \right)^2 \frac{1}{\nu_a} \frac{1}{1 + (E/T_a)^2 (T_a/(r B_o \nu_a))^2} \quad (4)$$

where R_o is major radius, B_o is the magnetic field on axis, ν_a is the collision frequency of species a . Equation (1) then becomes

$$\frac{\partial \mathcal{E}}{\partial \tau} - \frac{\partial^2 \mathcal{E}}{\partial \eta^2} = - \frac{(\mathcal{E}^3 + \alpha \mathcal{E} + \beta)}{\left(1 + \mathcal{E}^2 (d_e/n)^2\right)} \frac{1}{\left(1 + \mathcal{E}^2 (d_i/n)^2\right)}. \quad (5)$$

In (5), $\alpha_a = n(T_i/T_a)^2 T_a / (a_p r B_o \nu_a)$ where a_p is the plasma radius. \mathcal{E} is defined by $\mathcal{E} = a_p E/T_i - \tilde{A}_n/3$ with $\tilde{A}_n = -(n'/n) a_p (d_e \alpha_i^2 - d_i \alpha_e^2) / (d_e \alpha_i^2 (T_i/T_e) + d_i \alpha_e^2)$ and $d_a = (n/12) (T_a / (B_o R_o))^2 / (\nu_a a_p^2)$. The dimensionless time τ is defined by $\tau = t / ((\epsilon_{\perp} T_i / (n e a_p^2)) n^3 / (\alpha_i^2 d_e (T_i/T_e) + d_e^2 d_i))$ while $\eta = r / \epsilon_t / (D T_i / (n a_p^2 e) n^3 / (\alpha_i^2 d_e (T_i/T_e) + \alpha_e^2 d_i))^{1/2}$. The parameters α and β in (5) are given by $\alpha = R - \tilde{A}_n^2/3$ and $\beta = \tilde{A}_n Q (R/(3Q) - 1) - 2 \tilde{A}_n^3/27$ where $R = n^2 (d_e (T_i/T_e) + d_i) / (\alpha_i^2 d_e (T_i/T_e) + \alpha_e^2 d_i)$ and $Q = (d_e - d_i) n^2 / (d_e d_i^2 - d_i d_e^2)$. The parameters α and β are functions of radius through their dependency on $n(r)$, but on the scale on which $\eta = 0(1)$ this spatial variation can be

neglected. A good approximation to (5) is

$$\frac{\partial \mathcal{E}}{\partial \tau} - \frac{\partial^2 \mathcal{E}}{\partial \eta^2} = -(\mathcal{E}^3 + \alpha \mathcal{E} + \beta) \quad (6)$$

since it is clear that the positive definite denominators on the righthand side of (5) will only cause τ and η to be rescaled by some \mathcal{E} dependent factor. Hence, they will cause some distortion of the solitary wave associated with (6) without introducing any different physical content.

In (6), the cubic on the right hand side can have one or three real roots. The condition for three real roots is $\alpha^3/27 + \beta^2/4 \leq 0$ which implies a necessary condition of $\alpha < 0$. From the definition of α and β this can be satisfied at the edge of the plasma where the density gradient is the steepest. On the range $\eta \in (-\infty, \infty)$ three steady state solutions of (6) are obvious. If the three roots of the cubic are $\mathcal{E}_1, \mathcal{E}_2, \mathcal{E}_3$ ordered such that $\mathcal{E}_1 < \mathcal{E}_2 < \mathcal{E}_3$ then $\mathcal{E} = \mathcal{E}_i, i = 1, 2, 3$ is a steady state solution of Eq. (6). Furthermore, if we write the RHS of (6) as $-V'(E)$ then the solutions $\mathcal{E}_i, i = 1, 2, 3$ are the stationary points of $V(E)$. From (6) we can easily see by usual linear stability analysis that minima of $V(E)$ are stable while maxima are unstable. By integration of the RHS we see that \mathcal{E}_1 and \mathcal{E}_3 are minima and hence stable while \mathcal{E}_2 is necessarily a maxima of $V(E)$ and hence unstable to small perturbations.

We also know from the analysis leading to (3) that (6) has a solitary wave solution. For (6) an explicit analytic form for the ambipolaron is

$$\mathcal{E}(\tau, \eta) = u(\eta - c\tau) = u(z) = \frac{A}{2}(\tanh kz - d), \quad (7)$$

where $d = D/A$ and the offset, D , satisfies the cubic

$$D^3 + \alpha D + \beta = 0. \quad (8)$$

The amplitude A satisfies

$$A^2 = -3D^2 - 4\alpha \quad (9)$$

(note that $\alpha < 0$ for three real roots and hence A is real), the wave vector k satisfies

$$k = \frac{|A|}{2\sqrt{2}} \quad (10)$$

and the wave velocity c is determined in terms of the offset by

$$c = \frac{3d}{4} \left(\frac{A^2}{k} \right) \quad (11)$$

With A given by (9), the three roots of the cubic are D , $-A(1+d)/2$, $A(1-d)/2$. Hence we can see that if we choose one of the roots of the cubic to be D then the ambipolaron expressed by (7) will have asymptotic limits on the other two roots. This means that there are six solitary waves represented by (7). Three arise because we can choose any one of the roots of the cubic to be D while for each D , A can take positive or negative values as is clear from (9). We can also see that if one asymptotic limit of the ambipolaron is a stable root \mathcal{E}_1 or \mathcal{E}_3 and the other is \mathcal{E}_2 then we necessarily have $V(\mathcal{E}_2) - V(\mathcal{E}_{1,3}) > 0$ and so the stable root will be the dominant root. That is, the solitary wave will always propagate so as to annihilate the unstable root and increase the stable root. Note however that this annihilation will only be linear in time whereas if $\mathcal{E} = \mathcal{E}_2$ for $\eta \in (-\infty, \infty)$ then the plasma will decay exponentially fast away from \mathcal{E}_2 .

In Figure 1 we show three of the ambipolarons for $\mathcal{E}_2 < 0$ and $\mathcal{E}_2 > 0$. For $\mathcal{E}_2 < 0$ we have $V(\mathcal{E}_3) < V(\mathcal{E}_1)$; hence the ambipolaron with asymptotic limits \mathcal{E}_3 and \mathcal{E}_1 will propagate so as to enhance \mathcal{E}_3 and annihilate \mathcal{E}_1 . For $\mathcal{E}_2 = 0$, $V(\mathcal{E}_3) = V(\mathcal{E}_1)$ and the ambipolaron will be stationary. For $\mathcal{E}_2 > 0$, $V(\mathcal{E}_3) > V(\mathcal{E}_1)$ and the ambipolaron will propagate so as to annihilate \mathcal{E}_3 . In Figure 2 we draw the (β, α) space where three real roots occur and indicate the regions where $c_2 > < 0$. The velocity c_i is the velocity of the wave with $D = D_i$ ($i = 1, 2, 3$).

We observe the similarity between this analytic form for ambipolarons and kinks which occur in ϕ^4 field theory.¹⁻⁴ Kinks have the form

$$\phi_k = \pm \tanh\left(\frac{\eta - \eta_0}{\sqrt{2}}\right)$$

for any constant η_0 and satisfy the steady state nonlinear Klein-Gordon equation which is

$$\frac{\partial^2 \phi}{\partial \tau^2} = \frac{\partial^2 \phi}{\partial \eta^2} - [\phi^3 - \phi] = 0 \quad .$$

This corresponds to choosing $\beta = 0$, $\alpha = -1$ in (8) and then taking the root $D = 0$ which gives $c = 0$. Unlike the theory of kinks, the nonlinear diffusion equation is not invariant under a change in the direction of time. This will lead to significant differences between the interactions of two ambipolarons and the interactions of two kinks. However (6) is invariant under the change $\eta \rightarrow \eta - \eta_0$ for any η_0 ; hence in (7), if $u(z)$ is a solution of (6) then $u(z+a)$ for any constant a is also a solution. This is just the statement of translation invariance.

IV. Linear stability of ambipolarons

We can investigate the linear stability properties of those ambipolaron solutions in the following manner. We define $\psi(z, \tau)$ by $\mathcal{E}(\eta, \tau) = u(z, \tau) = \psi(z, \tau)e^{-cz/2}$. Then (6) becomes

$$\frac{\partial \psi}{\partial \tau} = -\frac{\delta F[\psi]}{\delta \psi} \quad (12)$$

where the Liapunov functional $F[\psi]$ is defined by

$$F[\psi] = \int_{-\infty}^{\infty} dz \left\{ \frac{(\psi')^2}{2} + \frac{\psi^2}{2} \left(\frac{c^2}{4} + \alpha \right) + \frac{\psi^4}{4} e^{-cz} + \beta \psi e^{cz/2} \right\}, \quad (13)$$

with $\delta/\delta\psi$ being the functional derivative. If we denote the ambipolaron by ψ_A ($\psi_A = e^{cz/2}(A/2)(\tanh kz - d)$) then it satisfies $\delta F[\psi_A]/\delta\psi = 0$. Furthermore, it is stable if $\delta^2 F/\delta\psi^2 > 0$, and a necessary condition for asymptotic stability is $dF/d\tau \leq 0$ where equality is achieved when $\psi = \psi_A$. The latter condition is automatic for equations of the form of (12), for $dF/d\tau = \int_{-\infty}^{\infty} (\delta F/\delta\psi) \partial\psi/\partial\tau dx = -\int_{-\infty}^{\infty} (\delta F/\delta\psi)^2 dx$. In order to verify the former we expand $F[\psi]$ about $F[\psi_A]$ by writing $\psi = \psi_A + \eta$ and obtain

$$F[\psi_A + \eta] = F[\psi_A] + \frac{1}{2} \int_{-\infty}^{\infty} dz \eta \left\{ \frac{-\partial^2}{\partial z^2} + \left(\frac{c^2}{4} + \alpha \right) + \frac{3A^2}{4} (\tanh kz - d)^2 \right\} \eta. \quad (14)$$

From (14), we see that if we solve the eigenvalue problem

$$\left[\frac{-\partial^2}{\partial z^2} + \left(\frac{c^2}{4} + \alpha \right) + \frac{3A^2}{4} (\tanh kz - d)^2 \right] \eta_m = \omega_m \eta_m \quad (15)$$

where the eigenvalues are $\omega_m, m \geq 0$ and $\omega_m \geq 0$ for all m , then we will have $\delta^2 F/\delta\psi^2 \geq 0$ and hence the ambipolaron in (7) will be linearly stable. Conversely if for any $m, \omega_m < 0$ then the ambipolaron is linearly unstable.

From the definition of c [(8)-(11)], we can see that for $d > (2/3)^{1/2}$ and $d < -(2/3)^{1/2}$, $c^2/4 + \alpha > 0$ which implies from the theory of Sturm-Liouville equations¹⁵ that all the eigenvalues ω_m are positive. In fact this is true for all d . To see this we write (15) as the Schroedinger equation

$$\frac{d^2 \eta_m}{dy^2} + \left[\hat{\epsilon}_m - 2U(y) \right] \eta_m(y) = 0 \quad (16)$$

where $y = Az/2\sqrt{2}$, $\hat{\epsilon}_m = 2(4\omega_m/A^2 - 2 - (9/2)d^2)$ and the potential $2U(y)$ is given by $2U(y) = -6\text{sech}^2 y - 12d \tanh y$. We note from the definition of $U(y)$ that (16) is

invariant under the transformation $d \rightarrow -d, y \rightarrow -y$ hence we need only consider (16) for $-1 < d \leq 0$. For $d = 0$, $U(y)$ is a symmetric well in which the quasiparticle described by (16) moves. It is well known that for a symmetric well we can expect to find bound states (discrete eigenvalues) as well as continuum eigenvalues. As $d \rightarrow -1$ the well becomes more and more asymmetric and we can expect to find bound states can fit in the well and only continuum states will exist. This Schroedinger equation (16) can be solved exactly¹⁶. It is found that for $-1/6 < d \leq 0$, there are two discrete eigenvalues as well as continuum states. The two discrete eigenvalues are, for $m = 0$,

$$\omega_0 = 0, \quad \eta_0(y) = e^{3dy} \text{sech}^2 y \quad (17)$$

and for $m = 1$

$$\omega_1 = \frac{A^2}{4} \left(\frac{3}{2} - \frac{27}{2} d^2 \right), \quad \eta_1(y) = e^{\delta dy} \text{sech} y \left(1 - \frac{1}{1-3d} + \frac{\tanh y}{1-3d} \right). \quad (18)$$

The continuum eigenvalues satisfy $\omega_k > \omega_1$. We can see from (17) and (18) that therefore $\omega_m \geq 0$ for all m . For $-2/3 < d \leq -1/6$, only the $m = 0$ discrete eigenvalue exists. For $-1 \leq d \leq -2/3$, only the continuum eigenvalues exist. The eigenfunctions for $d > 0$ can be obtained by replacing y by $-y$ in (17) and (18). The $m = 0$ eigenfrequency is the translation mode. This also exists for the kink in ϕ^4 theory. Such a mode must exist since as pointed out previously $z \rightarrow z + a$ in $u(z)$ will still give a solution to (6). The form of the eigenfunction in (17) follows since $\eta \propto \psi_A(z + \delta z) - \psi_A(z) = \delta z \partial \psi_A / \partial z$. The $m = 1$ eigenfunction corresponds to the shape mode found in ϕ^4 theory. This is a perturbation on the shape of the ambipolaron around $z = 0$ which vanishes for $z \rightarrow \pm\infty$.

We have shown that for all values of $d, \omega_m \geq 0$. Hence we arrive at the conclusion that except for the neutrally stable translational mode, the ambipolaron solution (7) to (6) is linearly stable. This is true even if one of the asymptotic limits of the ambipolaron is the unstable solution \mathcal{E}_2 . We speculate that this surprising conclusion is related to the result from quantum field theory⁸ that the kink solution is completely stable since the potential barrier in function space separating $\mathcal{E} = u(z)$ from $\mathcal{E} = \mathcal{E}_{1,2,3}$ is in some sense infinite.

V. Generalized ambipolarons

We have shown that (2) possesses solitary wave solutions. More generally it can be shown that nonlinear diffusion equations of the form

$$\frac{\partial E}{\partial t} = \frac{\partial^2 E}{\partial \eta^2} + f(E) \quad (19)$$

possess unique bounded solitary wave solutions¹⁰ under some relatively weak conditions on $f(E)$. The theorem in Ref. 10 states that if $f(E) = 0$ for $E = E_1, E_3$ and $f'(E_1) < 0$, $f'(E_3) < 0$ with $f(E) < 0$ for E near E_1 and $f(E) > 0$ for E near E_3 then there exists a unique bounded solitary wave solution of (19) $u(\eta - ct)$ with $u(-\infty) = E_1$, $u(\infty) = E_3$ and $E_1 \leq u \leq E_3$.

We note that the ambipolaron with $D = D_2$ (the intermediate root of (8)) satisfies the requirements of the theorem in Ref. 10 and hence is unique. However if $D = D_1$ or D_3 then one of the limits of the ambipolaron is D_2 which has $f'(D_2) > 0$. Hence the requirements of the theorem are not satisfied for this ambipolaron. This raises the question of whether it is unique. As a partial answer to this question we have studied (6) for the special case $\beta = 0$ to see whether other solutions are possible.

If we substitute $u(z) = u(\eta - ct)$ in (6) we obtain the ODE

$$u'' + cu' - (u^3 + \alpha u + \beta) = 0 \quad (20)$$

where $u' = du/dz$. We shall look for solutions of (20) of the form

$$u(z) = f(z)/g(z), \quad (21)$$

where

$$f = a_o + a_+ e^{kz} + a_- e^{-kz}, \quad (22)$$

$$g = b_o + b_+ e^{kz} + b_- e^{-kz}. \quad (23)$$

The ambipolaron solution in (7) is obtained by taking $a_o = b_o = 0$, $a_+ = A/2(1 - D/A)$, $a_- = -A/2(1 + D/A)$, $b_+ = b_- = 1$. Clearly the form for $u(z)$ in (21) is a generalization of the solitary wave form in (7). We define $\sigma = \pm 1$ and

$$D_\sigma = a_\sigma/b_\sigma, a = a_o/b_o \quad (24)$$

$$B = b_+ b_- \quad (25)$$

then a solution like (21) exists if and only if the following seven relations are satisfied

$$b_\sigma^2 (D_\sigma^3 + \alpha D_\sigma + \beta) = 0 \quad (26)$$

$$B_\sigma^2 b_o \left\{ -k(k - \sigma c)(a - D_r) + 3(aD_\sigma^2 + \beta) + \alpha(2D_\sigma + a) \right\} = 0 \quad (27)$$

$$\begin{aligned}
b_\sigma \left\{ k^2 \left[b_o^2 (a - D_\sigma) + 4\sigma B (D_+ - D_-) \right] + \sigma ck \left[b_o^2 (a - D_\sigma) - 2\sigma B (D_+ - D_-) \right] \right. \\
+ 3B (D_\sigma D_+ D_- + \beta) + 3b_o^2 (a^2 D_\sigma + \beta) \\
\left. + 2B (D_{-\sigma} + 2D_\sigma) + \alpha b_o^2 (D_\sigma + 2a) \right\} = 0
\end{aligned} \tag{28}$$

$$\begin{aligned}
b_o \left\{ -3k^2 B (D_+ + D_- - 2a) - 3ck B (D_+ - D_-) + 6B\beta + 6Ba D_+ D_- \right. \\
\left. + b_o^2 a^3 + b_o^2 \beta + 2\alpha B (D_+ + D_- + a) + \alpha a b_o^2 \right\} = 0.
\end{aligned} \tag{29}$$

We note that b_+ and b_- occur only in the combination $B = b_+ b_-$. This is because (20) is invariant under translation in z hence the solution (21) must remain a solution upon translation. The ambipolaron solution can be obtained from the set (26)-(29) when b_o and a vanish.

We now consider (26)-(29) for the special case $\beta = 0$ and show that there are other nonlinear solutions to (20). For bounded solutions at $z \rightarrow \pm\infty$ we want $b_\sigma \neq 0$; hence, from (26)

$$D_\sigma^3 + \alpha D_\sigma = 0. \tag{30}$$

We take $\alpha < 0$ (for three real roots); then $D_\sigma = 0, \pm\sqrt{-\alpha}$. If we choose $D_\sigma = 0$ then from (27) we obtain $\alpha = k(k - \sigma c)$ and therefore $c = 0, \alpha = k^2$. From (28) we find $b_o^2 (k^2 + 2\alpha) = 0$ whence $b_o = 0$ and only the $a_o = ab_o$ terms in (18) survive. These yield $8Bk^2 + a_o^2 = 0$ which implies $B > 0$ and

$$a_o = 2\sqrt{2B}\sqrt{-\alpha}.$$

This completes the solution for $D_\sigma = 0$, which can be written

$$u = \sqrt{2}\sqrt{-\alpha} \sec \left(\sqrt{-\alpha}(z + z_o) \right) \tag{31}$$

for any constant z_o . We note that it has spontaneous singularities in it (at $(z + z_o)\sqrt{-\alpha} = (2n + 1)\pi/2, n = 0, 1, 2, \dots$) and therefore is not the ambipolaron solitary wave.

We next show that when $b_o = 0$, the only possible solution either has $a_o = 0$ and hence corresponds to the ambipolarons or has $D_\sigma = 0$ and is the solution in (31). To prove this we note that when $\beta = b_o = 0$ (26)-(29) reduces to (30) together with

$$-k(k - \sigma c)a_o + 2a_o D_\sigma^2 = 0 \tag{32}$$

$$4\sigma k^2 B(D_+ - D_-) - 2ckB(D_+ - D_-) + 3BD_\sigma D_+ D_- + 3a_o^2 D_\sigma - D_\sigma^2 B(D_{-\sigma} + 2D_\sigma) = 0 \quad (33)$$

$$6Bk^2 a_o + 6Ba_o D_+ D_- + a_o^3 - 2D_\sigma^2 B a_o = 0 \quad (34)$$

where we have used $D_\sigma \neq 0$ to infer $\alpha = -D_\sigma^2$ from (30). It is clear that (32) has two classes of solution depending on whether a_o vanishes. If $a_o = 0$ one obtains from (33) that $D_+ - D_- = A = 8k^2$ which is the $\beta = 0$ limit of (7). Hence we take $a_o \neq 0$. Then (34) gives

$$a_o^2 = 2B(D_\sigma^2 - 3k^2 - 3D_+ + D_-).$$

From (32) we obtain $c = 0$ and $k^2 = -2D_\sigma^2$ which give in (34)

$$5D_\sigma^2 - 2D_+ D_- - \sigma D_\sigma (D_+ - D_-) = 0. \quad (35)$$

However $k^2 = -2D_\sigma^2$ implies that $D_- = \pm D_+$ which on substitution in (35) indicates that there is no solution for $D_\sigma \neq 0$. Hence we see that for $\beta = 0 = b_o$ the only regular, bounded solutions of the form (21)-(23) are the ambipolaron solutions.

In a similar manner we can obtain the solutions of the form (21) when $b_o \neq 0$. The solutions require $\alpha = -m^2 < 0$ and are specified by

$$c = 0, k^2 = 2m^2, \quad (36)$$

$$D_+ = -D_- = m\tau, \quad \tau = \pm 1, \quad (37)$$

$$b_o^2/B = 4m^2/(m^2 - a^2), \quad (38)$$

and

$$s = \text{sgn}(m^2 - a^2). \quad (39)$$

The parameter a is free. The solution is then

$$u(z) = m \frac{[2a + \mu\tau\sqrt{|m^2 - a^2|}(\zeta - s/\zeta)]}{[2m + \mu\sqrt{|m^2 - a^2|}(\zeta + s/\zeta)]} \quad (40)$$

where $\zeta = e^{k(z+z_o)}$, $\mu = \pm 1$, $\tau = \pm 1$, and $s = \pm 1$. The parameter μ arises from the solution to (28). All three signs can be chosen independently, although a and s must be

chosen consistently with (39). Thus (40) has eight distinct families of solutions. If $a = 0$ then one finds two solutions

$$u = m \tanh(kz/2) \quad (41)$$

and

$$u = m \operatorname{ctnh}(kz/2). \quad (42)$$

The solution in (41) is the $D = 0$ limit of (7). The solution given by (32) is new but has spontaneous singularities in it (at $z = 0$). For $a \neq 0$ there are obviously bounded solutions in (40) ($s = +1, \mu = +1$). However they are all translations of (41). We show this in the following manner. Supposing first that $m > a$, we introduce θ such that

$$\begin{aligned} a / \left[\sqrt{m^2 - a^2} \right] &= \sinh \theta, \\ m / \left[\sqrt{m^2 - a^2} \right] &= \cosh \theta, \end{aligned}$$

We also let $\phi = k(z + z_0)$. Then, since $s = 1$ for $m > a$, we can write

$$u = m(\sinh \theta + \tau \sinh \phi) / (\cosh \theta + \cosh \phi).$$

Using elementary identities one finds that

$$u = m \tanh \left[(\theta + \tau \phi) / 2 \right], \quad \text{for } m > a.$$

Thus (40) is simply a displacement of (41).

For $m < a$, the definitions of $\sinh \theta$ and $\cosh \theta$ are interchanged (since we must have $\cosh^2 - \sinh^2 = 1$), and $s = -1$. The result is to yield the above, $\tanh(\theta - \phi)/2$, solution when $\tau = -1$ and

$$u = m \operatorname{ctnh} \left[(\theta + \phi) / 2 \right] \quad \text{for } m < a,$$

when $\tau = 1$. Of course this generalizes (42). Hence we conjecture that for $\beta = 0$ the ambipolaron solution is the only bounded nonlinear solution to (20). We speculate that for $\beta \neq 0$ the same conclusion holds even when the conditions on $f(E)$ after (19) are not satisfied.

VI. Collisions of ambipolarons

An important difference between a solitary wave and a soliton is that solitons are solitary waves which interact with each other in such a way that the original structure of each soliton is unchanged after the interaction. In this section we have numerically examined the interaction of two ambipolarons in order to elucidate the nature of these solitary waves.

The nonlinear diffusion equation (6) was solved by a split-step fast Fourier transform method.¹⁷ The linear dispersion was solved exactly in the Fourier space and the nonlinear terms advanced in time by using the partially corrected 2nd order Adams-Bashforth scheme.¹⁸ Typically computations used 2^7 grid points and a time step of 0.002.

The initial condition for (6) was chosen to be

$$E(\eta, t = 0) = \left[\frac{A}{2} \tanh k(\eta + \eta_o) - \frac{D}{2} \right] + \left[-\frac{A}{2} \tanh k(\eta - \eta_o) - \frac{D}{2} \right] - \left[\frac{A}{2} - \frac{D}{2} \right]. \quad (43)$$

This is the sum of an ambipolaron and an anti-ambipolaron ($A \rightarrow -A$) situated at $\eta = -\eta_o$ and $\eta = \eta_o$ respectively with an offset added so that they do not interfere with each other if they are widely separated. We can see this by noting that for $\eta \ll -\eta_o$, $E(\eta, t = 0) \rightarrow -(A + D)/2$, for $-\eta_o \ll \eta \ll \eta_o$, $E(\eta, t = 0) \rightarrow (A - D)/2$ and for $\eta \gg \eta_o$, $E(\eta, t = 0) \rightarrow -(A + D)/2$. Hence each solitary wave has the right asymptotic limits and each will be an (approximate) solution to (6) if $\eta_o \gg 1$.

Three types of time dependent solutions have been found. These are shown in Figures 3-5. If $D = D_1$ then from Figure 1 we see that the two ambipolarons will diverge. This is shown in Figure 3 where the wave fronts diverge with velocity given by (11) until they hit the boundary of the space and annihilate. As previously mentioned, the ambipolarons move in such a way as to enhance the stable root \mathcal{E}_3 at the expense of the unstable root \mathcal{E}_2 . If $D = D_2 = 0$ then each ambipolaron will remain stationary. This is observed in Figure 4 where the pulse-like structure composed of the two waves persists. This indicates that for $D_2 = 0$ this soliton-like structure is a steady state solution of (6). If $D = D_3$ then from Figure 1 the two ambipolarons will converge. This is seen in Figure 5 where the two waves converge at the speed given by (11) until they mutually annihilate each other leaving the system on the stable root \mathcal{E}_1 .

Thus unlike solitons the interaction of these solitary waves can cause their destruction. However a pulse-like solution can arise when two ambipolarons exist.

VII. Conclusions

Finally, if we return to dimensional variables we can obtain the size and speed of the ambipolarons in (7) for typical parameters. We take $a_p = 20\text{cm}$ with $T_e = T_i = 300\text{eV}$. The diffusion time $\tau_p \approx 10$ milliseconds while $\tau_E \simeq 1/50$ milliseconds. Therefore, the approximation used to decouple (1) from the density and temperature equation ($\tau_E \ll \tau_p$) is clearly satisfied. We choose a cubic density profile with $n(r = 0) = 5 \times 10^{13}$ and $n(r = a_p) = 1 \times 10^{13}\text{cm}^{-3}$. The three real roots for the RHS of (6) exist for the last 2cm of the plasma. The electric fields in this region are in the range 15-150V/cm. The length scale over which the ambipolaron changes is of the order of 0.2cm which is a few ion gyroradii. The velocity of the ambipolaron is in the range $1 - 3 \times 10^6\text{cm/sec}$ which is much smaller than the ion thermal velocity which is $16 \times 10^6\text{cm/sec}$.

We conclude that these ambipolaron solitary waves could exist in an experiment. Unfortunately, no experiment to date has observed them. Future work will address the question of how these solitary waves are modified when α and β are allowed to be slow functions of space.

Acknowledgements

The authors would like to acknowledge useful discussions with S. Eliezer, K.C. Shaing and the help of Jim Meiss. One of the authors (DEH) would like to acknowledge the hospitality of the Institute for Fusion Studies, where this work was started. This research was sponsored in part by the Office of Fusion Energy, U.D. Department of Energy, under contract DE-AC05-84OR-21400 with Martin Marietta Energy Systems, Incorporated. This work also supported by DOE Contract #DEFG-05-80ET-53088.

References

1. R. Rajaraman, Phys. Reports **21**, 227 (1975).
2. T. Sugiyama, Prof. Theor. Phys. **61**, 1550 (1979).
3. D.K. Campbell, J.F. Schonfeld and C.A. Wingate, Physica **9D**, 1 (1983).
4. M. Peyrard and D.K. Campbell, Physica **9D**, 33 (1983).
5. P.J. Morrison, J.D. Meiss and J.R. Cary, Physica **11D**, 324 (1984).
6. M.J. Ablowitz and H. Segur, *Solitons and the Inverse Scattering Transforms*, (SIAM, Philadelphia, 1981).
7. D.E. Hastings, Phys. Fluids **28**, 334 (1985).
8. H.E. Myrick and W.N.G. Hitchon, Nucl. Fusion **23**, 1053 (1983).
9. K.C. Shaing, Phys. Fluids **27**, 1567 (1984).
10. P.C. Fife and J.B. McLeod, Bull. Amer. Math. Soc. **81**, 1075 (1975).
11. R.A. Fisher, Ann. of Eugenics **7**, 355 (1937).
12. J. Nagums, S. Arimoto and S. Yashizawa, Proc. Just. Radio Eng. **50**, 2061 (1962).
13. P.C. Fife, J. Chem. Phys. **64**, 554 (1976).
14. L. Kovrizhnykh, Sov. Phys. JETP, **29**, 475 (1969).
15. P. Morse and H. Feshbach, *Methods of Theoretical Physics*, (McGraw-Hill, 1953, New York) p.736.
16. *ibid*, p. 1651.
17. F. Tappert, Lect. Appl. Math **15**, 215 (1974).
18. J. Gazdag, J. Comp. Phys. **20**, 196 (1976).

Figure captions

1. The three ambipolarons for $A > 0$ and $\mathcal{E}_2 >< 0$.
2. (β, α) space showing the regions where $c_2(\leq)(\geq)0$.
3. Two diverging ambipolarons ($\alpha = -1, \beta = 0, x_o = 10, D = D_1 = -1$).
4. Two stationary ambipolarons ($\alpha = -1, \beta = 0, x_o = 10, D = D_2 = 0$).
5. Two converging ambipolarons ($\alpha = -1, \beta = 0, x_o = 10, D = D_3 = 1$).

ORNL-DWG 85-2682 FED

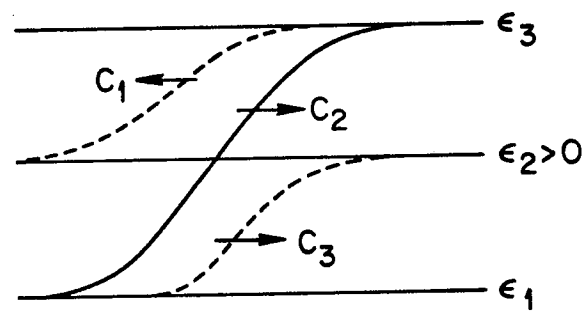
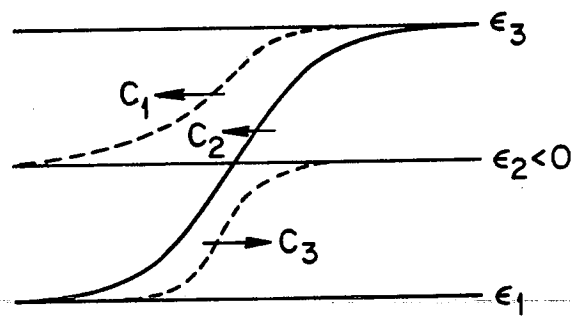

Fig. 1

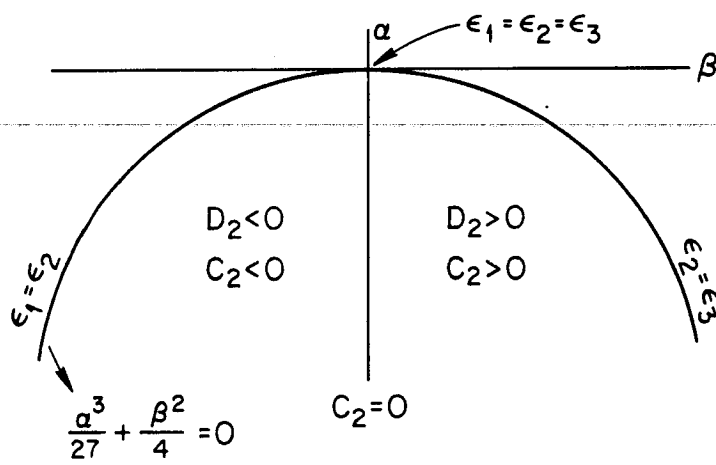

Fig. 2

ORNL-DWG 85-2684 FED

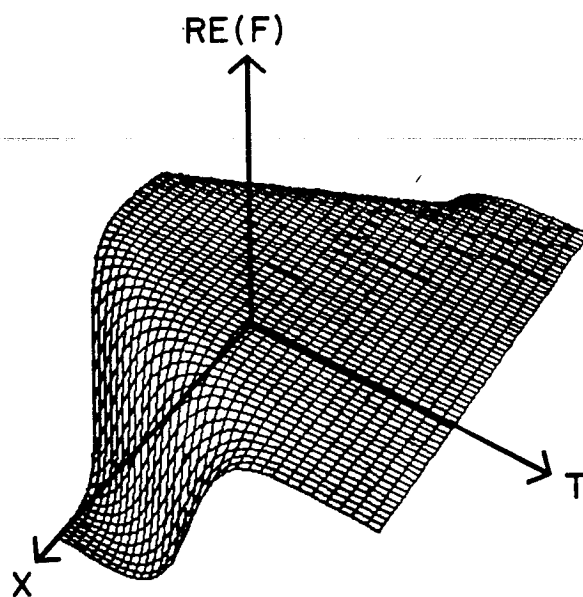

Fig. 3

ORNL-DWG 85-2685 FED

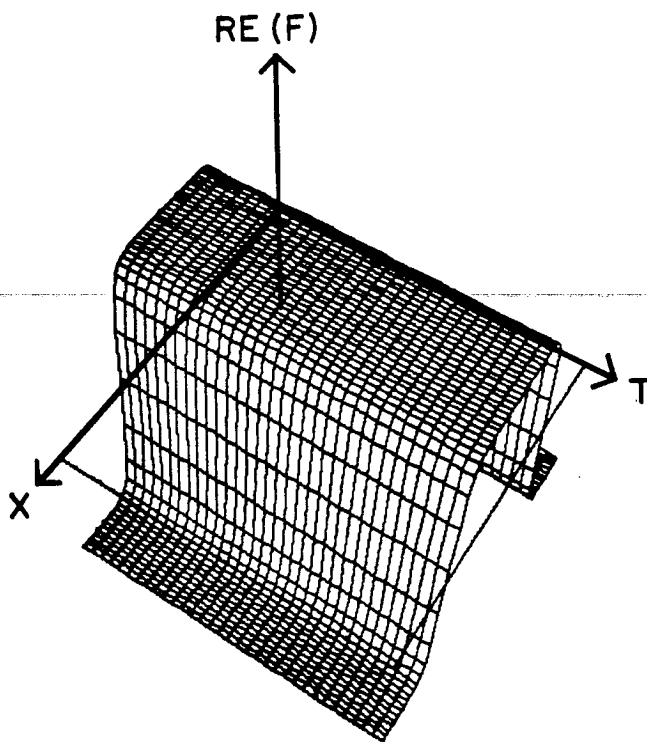

Fig. 4

ORNL-DWG 85-2686 FED

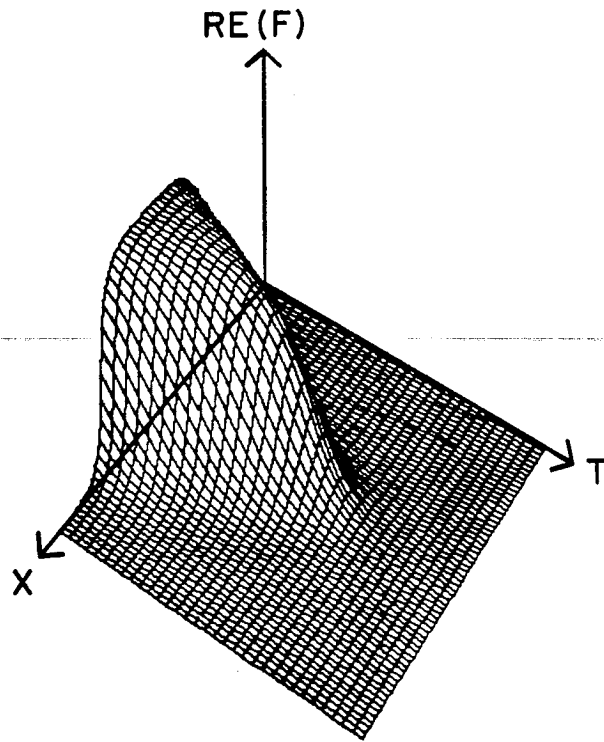

Fig. 5